

Steel-net rockfall protection – experimental and numerical simulation

H. Grassl¹, A. Volkwein², E. Anderheggen² & W.J. Ammann¹

¹*Swiss Federal Institute of Snow and Avalanche Research SLF
Flüelastrasse 11, CH-7260 Davos Dorf, Switzerland.*

²*Institute of Structural Engineering, Federal Institute of
Technology, ETH Hönggerberg, CH-8093 Zürich, Switzerland.*

Abstract

The design of today's state-of-the-art rockfall barriers is currently based on experience and time-consuming experimentation. Advanced simulation models are now under development to reduce prototyping time and development costs and will also provide a better understanding of complex mechanical systems under impact.

In order to develop the models, extensive field testing was carried out. The individual components of the barriers were dynamically tested on a specially designed field apparatus. High energy full-scale tests on instrumented multi-span systems were additionally performed.

The newly developed finite element program simulating the barriers is based on an explicit time step algorithm combined with special-purpose elements with large deformations and nonlinear material behavior for the net and brake-rings. For the interaction of rock and elements it also considers contact and sliding effects as well as friction.

1 Introduction

Rockfall is a threat to the inhabitants and infrastructure of mountain regions. In Switzerland approximately US\$ 6 million per year are invested in new protective structures. Many existing structures must be replaced since they no longer comply with modern safety requirements.

Rockfall protection with flexible steel-net systems has significantly increased compared with other protective measures because of its advantageous ratio of energy absorbing capacity and cost. Within the last twelve years the energy absorbing capacity of steel-net systems has improved by a factor ten. Steel-net systems consist of wire-ring nets or diagonal-rope nets, steel cables, inelastic brake elements and columns. These fence-like structures are installed above transportation lines and residential areas to stop falling rocks with masses of up to 10 tons and velocities of up to 60 mph. This corresponds to a maximum energy absorbing capacity of 3000 kJ. Due to their high deformation capacity with displacements up to 8 m the systems absorb 50 times higher kinetic energies than conventional structures of rigid steel or wood.

Although plenty kilometers of these barriers have been constructed worldwide, their design is still based on ad-hoc procedures. Without the knowledge of the deformation behavior of the systems, loads acting on the system can only be specified in terms of impact energy rather than in applied forces [1]. Comprehensive testing programmes have been carried out to measure the energy capacity and, depending on the use of measuring devices, to obtain additional information, such as cable forces [2]. However, testing procedures cannot provide complete information about stresses and strains in the individual components as well as reactions at the support. Furthermore, 1:1 scale field tests are time and cost intensive.

For this reason, advanced simulation models were developed. A research project with the goal to combine specialized field experiments and numerical modeling was started in year 2000. This project is jointly carried out with the manufacturer of the ring nets, two research institutes and the financial support of the Swiss Federal Commission for Technology and Innovation (CTI) who encourages projects that fulfil economic and technical needs. The newly developed finite element program uses an explicit time step method and combines special purpose elements with large deformations, nonlinear materials, contact and sliding effects as well as friction. To calibrate and to verify the numerical simulation a multistage testing programme with new measuring methods was carried out. The finite element computer program will contribute to reduce prototyping time and development cost. Furthermore, the program will enable practitioners for the first time to rationally develop rockfall protection systems.

2 Methods

The experimental research and the development of numerical models proceeded simultaneously. The experimental programme consisted of quasi-static laboratory experiments and dynamic field experiments divided into four well defined stages.

2.1 Quasi-static laboratory experiments

To determine the non-linear behavior and the energy capacity of the wire rings, quasi-static tensile tests were performed in laboratory. Different configurations of single rings and groups of rings were investigated (see Figure 1). The multi-ring tests were also used to determine the rubbing friction between the rings.

The 300 mm diameter net ring consists of 3 mm steel wire windings. The number of windings depends on the desired ring resistance. The yield stress of the steel is 1770 N/mm^2 .

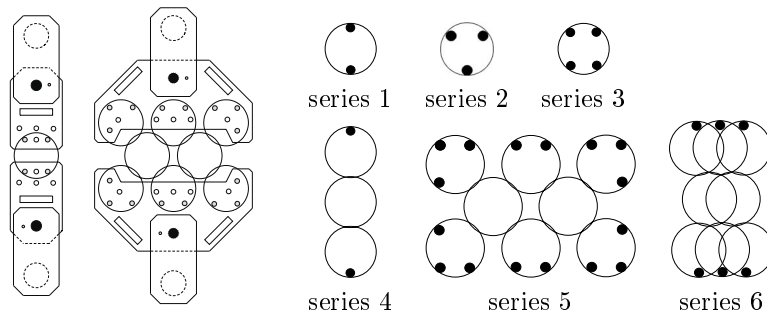

Figure 1: Quasi-static tensile tests with wire rings \varnothing 300 mm: Apparatus and overview of test series

2.2 Dynamic field experiments

2.2.1 Test Site

The field tests were performed in the Swiss Federal Rockfall Test Site near Walenstadt in Canton St. Gallen. The site is used for type-testing, research purposes and product development. The boulders have a maximum mass of 16 tons and are released from a crane. They can be dropped a vertical distance of up to 60 m before the impact with the protection systems. To prevent ground contact during the deceleration phase the complete systems with three fields are installed in a vertical rock face 15 m above the ground. The free fall test guarantees the reproducibility of the velocity, the (vertical) trajectory and the location of the impact.

2.2.2 Testing programme

The dynamic behavior of the single components is investigated using a specially constructed field apparatus. High energy full-scale tests are performed on a complete system with three spans.

The experiments on the field apparatus, shown in Figure 2, are realized with system components in a simplified arrangement with reduced degrees of freedom. Three test stages were defined. During the first stage, square nets with blocked displacements at the boundary were measured. During

the second stage, square nets were suspended from cables and during the third stage, square nets were suspended from cables with integrated brake elements. This step-by-step procedure was selected in order to understand the behavior of the single elements within the system. Thus, single element models could be developed and tested. Furthermore, the simplified configuration reduces the number of model parameters and makes integral and accurate measurement possible.

After the individual components were tested dynamically, field tests with complete systems were performed. Both the simplified and full-scale tests were back-calculated with the finite element model.

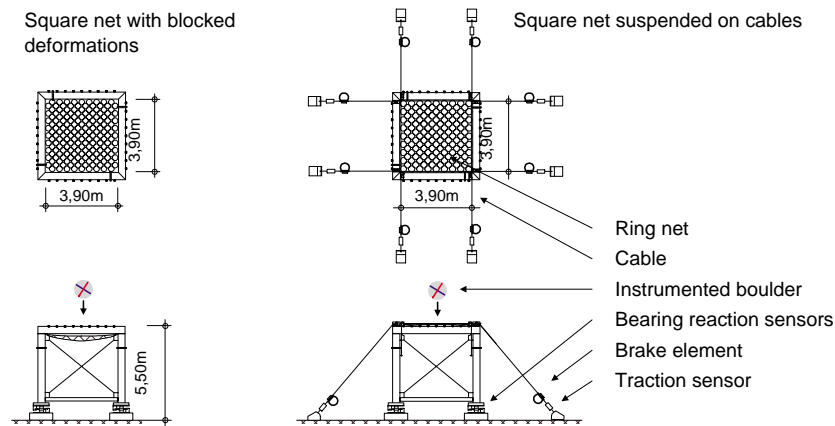

Figure 2: Plan and elevation of the field apparatus

2.2.3 Field apparatus

The field apparatus consists of a horizontal square frame supported by four columns. Figure 2 shows different installations of the nets with or without cables and brake elements according to stage one and stage three. The frame is located in the range of the crane which enables free-fall loading with maximum dropping heights of up to 32 m. The square nets measure 3.90 m \times 3.90 m.

2.2.4 Measuring techniques

Several measuring techniques are used to record the braking process of the boulder in the net. The horizontal and vertical bearing reactions were measured with load cells fixed at the four supports of the columns. Eight load sensors measured the tensile forces in the ropes. To avoid dynamic effects these sensors are directly fixed to the eight anchoring points surrounding the frame.

To obtain the resulting braking force which acts on the net in a direct manner, accelerometers and a computer control unit have been integrated in

the boulder. The boulder consists of two semi-shells of fiber reinforced high performance concrete with a total mass of 830 kg. This instrumented rock is dropped from heights of up to 32 m. The integral parts of the data acquisition system is a micro-controller and a 12 bit A-D transformer. The data are sampled with 20 kHz and written continuously in a ring buffer. After triggering the data are retained in the static RAM-memory until down-loading is completed. This deceleration is tracked with eight capacity accelerometers. The range of the sensors is ± 50 g with guaranteed overload of maximum 1000 g. The accelerometers measure the stone's deceleration over time. A special integration procedure has been developed to obtain the velocity and position of the rock.

Beside the force sensors and the accelerometers, the third independent measuring technique is a high speed video system with two cameras recording 250 frames per second. The video system is synchronized with the force sensors. These recordings document the entire braking process.

2.3 Numerical modeling

A special purpose computer program based on the finite element method and capable of numerically simulating the dynamic behavior of many types of barriers is being developed. The time dependent processes are described with an explicit time step algorithm based on the Central-Differences-Method which assumes equilibrium between element and external forces for smallest time intervals. Contrary to implicit calculations - where the equilibrium is in fact iteratively computed at each step - the time intervals have to be much smaller (in our case $dT \simeq 50\mu s$). The computing time needed at each step, however, is much smaller. The explicit method is also much better suited than the implicit for treating impact.

Typical for the explicit finite element analysis is the use of lumped mass matrices which means the concentration of all element masses onto their incidence nodes. The node movements are achieved by applied forces obtained from the contact and element algorithms. Those result in an acceleration of the concentrated masses as shown in Figure 3.

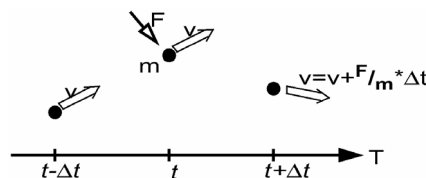

Figure 3: Functionality of the explicit algorithm

The intended application's use is the effective development of new protection systems. This can be achieved with a full interactive graphical user interface which allows a virtual reality 3D visualization of the rockfall absorbing process as demonstrated in Figure 4.

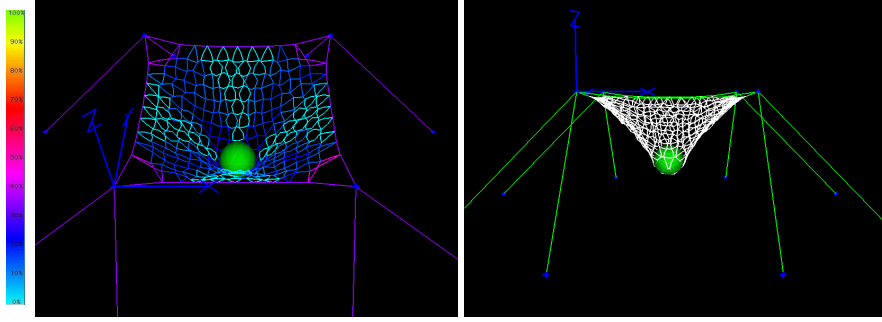

Figure 4: Simulation of single square, wire-ring net 3.90 m \times 3.90 m suspended on cables (Topview with degree of utilization of single elements)

Contrary to common FE-codes which use a post processor for visualizing the results after performed calculations, the visualization now takes place in real-time with the calculation. This avoids the collection and saving of large amounts of unneeded data and also allows the user to interrupt the simulation at any stage and to set restart points, e.g. for a second rock impact into the same protection system.

Next to the user friendly graphical environment, the possibility of freely defining the functionalities of the rock impact and the material behavior is an important feature of the new program.

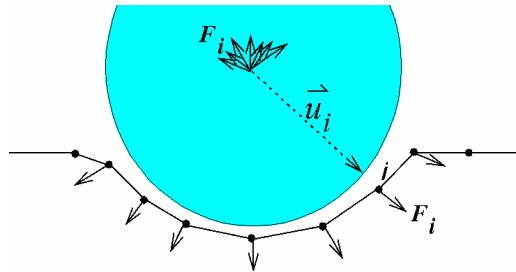

Figure 5: Contact computed with forces constraining the rock and the nodes

2.3.1 Impact calculations

Newly developed application software includes individually optimized features, such as an effective contact algorithm for simulating the impact of the rock into the net and maybe on other elements like cables or posts. For every single time step only the relevant model nodes are taken into account for computing the impact forces (see Figure 5). The approach for the contact forces,

$$\Delta E_{Rock} = \sum_{Nodes} \Delta E_i \quad (1)$$

where the loss of the rock's energy is equal to the increasing energy of the nodes involved in the contact, leads to an elastic contact. Plastic contact is computed with the condition, that the relative velocity of the nodes radial to the rock must be zero:

$$\vec{v}_{Rock} \circ \vec{v}_{Node} = 0 \quad (2)$$

The impact forces additionally lead to friction between the rock and the element nodes depending of their relative velocities and contact forces.

2.3.2 Special purpose elements

New and quite promising are the procedures used for modeling the protection system's components, especially for ring and brake elements. Their material behavior derived from quasi-static tests as described in section 2.1 was verified by using it for the simulation of the dynamic 1:1 field tests from section 2.2.

The diagram in Figure 6 shows the idealized behavior of a net ring and the four characteristic values to map this curve. They were adapted from the results of the quasi-static tests. In the lower part the ring's resistance only originates from its bending stiffness which is simulated through diagonal forces. Once the ring's curvature is almost straightened the resistance of axial strain in the rings is dominating and is modeled by forces acting between neighboring incidence nodes.

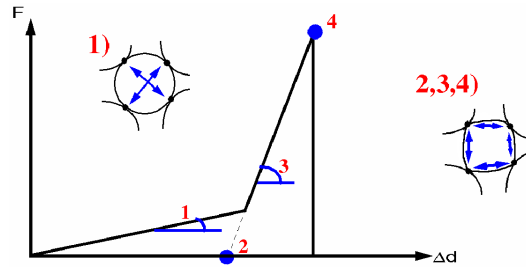

Figure 6: Modeling the net rings via single forces on their incidence nodes

Innovative is also the approach for handling sliding effects. Nodes containing cable masses can move freely along the cable. This was achieved by using a constant normal force for all cable segments determined by the cable length as the sum of the single node distances (see Figure 7).

Hence, several effects are considered such as sliding of rings within the net, so the net nodes can arrange themselves as they do in field tests. Also supported is sliding of the net along suspension cables and sliding of suspension cables over supporting posts or at their bounding joints. Friction is determined from the relative node velocities and the forces moving the nodes perpendicular to the elements's track.

The explicit time step algorithm allows an easy implementation of any nonlinear material behavior e.g. plasticity in normal strain and bending. Es-

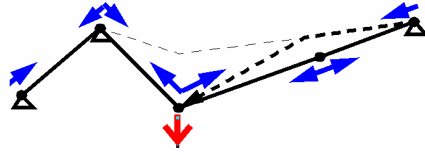

Figure 7: Cable element: constant normal force for all cable segments and node movements during three time steps

pecially the brake elements need a complex description of their deformations relating to the forces acting on them. Their behavior was determined by an extra finite element analysis, which was verified by quasi-static experiments, and is now integrated in the element library.

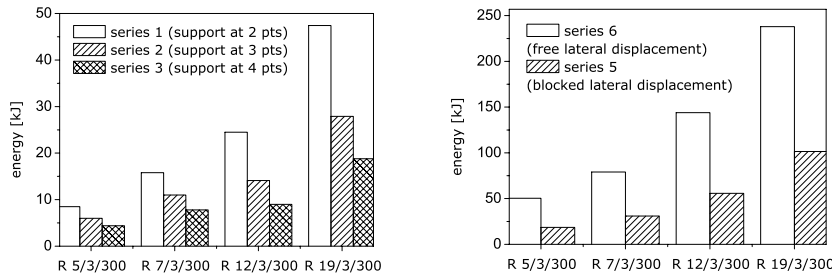

Figure 8: Energy capacity of single rings and ring groups (Rocco 5-19/3/300): Influence of winding number and boundary condition

3 Results

About hundred dynamic tests on the field apparatus and two tests with complete protection systems in a three field barrier have been performed. Discussed is a selection of those experiments corresponding to the state of development of the numerical simulation program.

3.1 Mechanical behavior

Figure 8 shows a comparison of the quasi-static energy absorbing capacity of single rings with different support and ring groups with free and blocked lateral displacement according to the test series shown in Figure 1. The wire ring types differ only in the number of windings (5, 7, 12, 19). Significant for the mechanical behavior of the rings during loading is the segmentation in a first zone where bending and in a second zone where axial strain is predominant. The stiffness due to bending is much smaller than the stiffness due to axial strain.

There is a significant influence of the boundary condition of the net regarding its energy absorbing capacity. The dynamic experiments on the

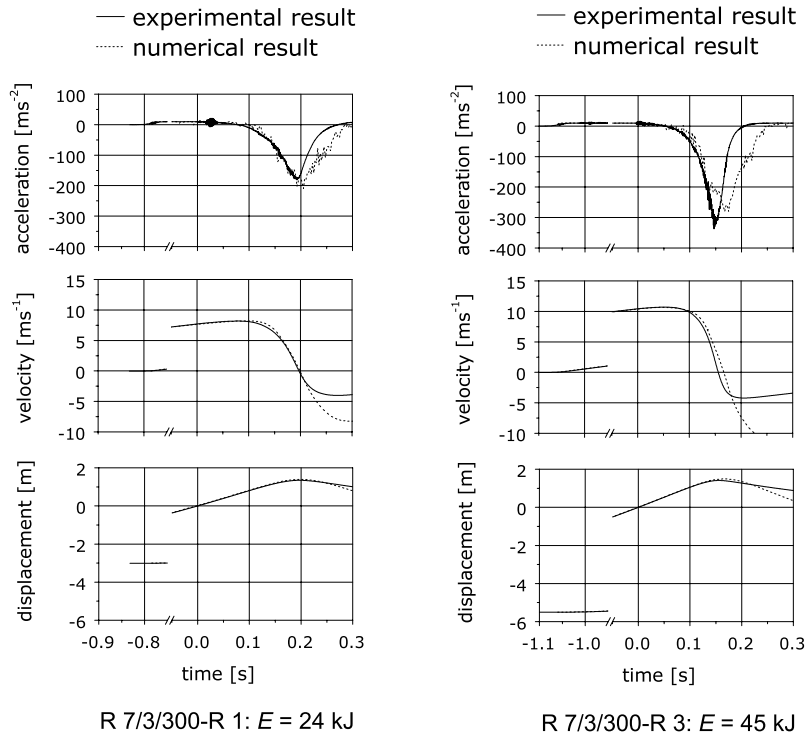

Figure 9: Single square, wire-ring net $3.90 \text{ m} \times 3.90 \text{ m}$ with blocked deformations: Data from the accelerometers in the boulder (vertical component)

field apparatus presented in Figure 2 show that a net suspended on cables absorbs three times more energy than a net of the same dimension with blocked displacements at the boundary. If brake elements are supplemented in the cable the energy capacity increases with a factor 1.5 in comparison with the net suspended on cables without brake elements. This shows that an increase of the energy absorbing capacity comes along with an increase of the braking distance of the rock in the protection system.

3.2 Comparison of experimental data and numerical modeling

Figure 9 shows the results of the experimental and numerical simulation of square nets with blocked displacement at the boundary. In Figure 10 square nets suspended on cables are compared for different load levels. The experimental data were measured by the instrumented boulder.

Plotted are the vertical components of the boulder's acceleration, velocity and displacement over time. The curves start from the time when the boulder is released from the crane. Point of time $t = 0.0 \text{ s}$ corresponds to the

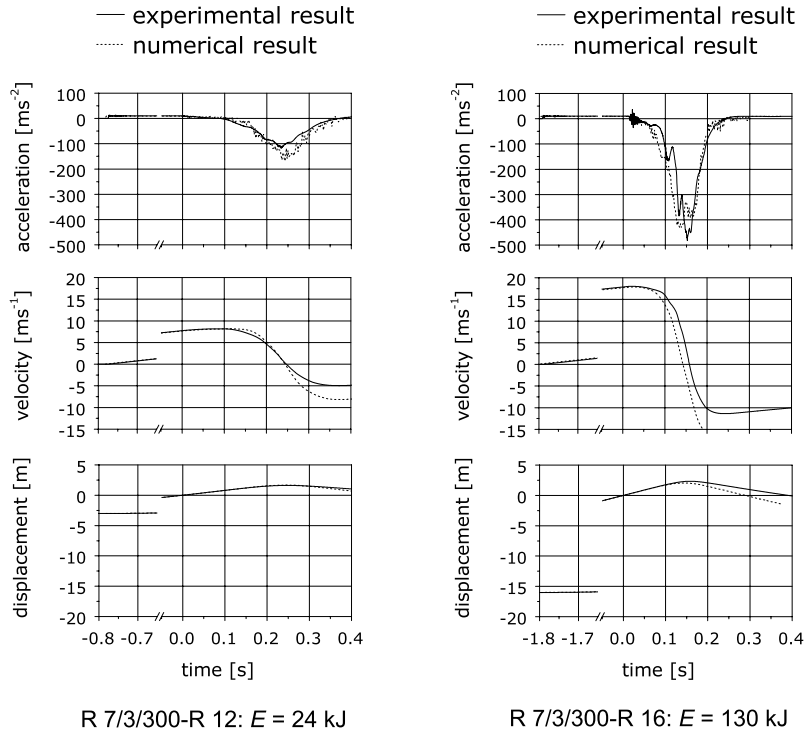

Figure 10: Single square, wire-ring net $3.90 \text{ m} \times 3.90 \text{ m}$ suspended on cables: Data from the accelerometers in the boulder (vertical component)

first contact of the boulder with the net. The minimum of the acceleration-time-relation corresponds to stillstand of the boulder. The phase of free-fall between releasing from the crane and first contact with the net is shortened for scale reasons. Because of the sequential step-by-step testing of the single net components (section 2.2.2) a direct comparison with the single numerical models is possible. For example, the experimental cable influence visible from the accelerations of test serie R 7/3/300-R 16 in Figure 10 was obtained from the simulation as well.

Even though the calibration of the numerical part is not yet completely finished a very good congruence to the experimental data was already achieved. Some differences between simulation and experiments rise after the impact when the rock is moving upwards again. For the actual state of the research project this is not very relevant because the focus is set on the time and place of the boulder's stillstand and the deceleration curve on the way to this point. The complete behavior is part of the last project's phase where it is important to know the residual capacity of the system e.g. for a second or even third rockfall event. It will consider more

plastic deformations and friction effects reducing the elastic behavior of the simulation.

4 Conclusions

A research project on protection systems against rockfall combining field experiments with numerical simulations was presented. The main object was the complete and detailed understanding of the behavior of flexible structures under impact. Because of the complexity of the systems, experimental investigation of the single components were necessary. The research on the single components provides the basis to describe the overall system behavior.

In the first phase a ring net model was developed with results from quasi-static field tests and verified through dynamic field tests with nets on fixed bearings. For the first time new measuring techniques like accelerometers in the boulder were successfully applied. The next step combined those nets with cable support which gives the net additional degrees of freedom. In the last step the system's components are to be completed with brake elements and finally verified respectively validated with the results of field tests on a complete rockfall protection system. Altogether, they will provide usable knowledge for further developments in the field of rockfall protection systems.

Acknowledgements

The authors wish to acknowledge the *Swiss Federal Commission for Technology and Innovation (CTI)*, which provided partial financial support for this work. Industrial partner is the Swiss company *Fatzer AG, Profitcenter Geobruigg, CH-8590 Romanshorn* with high technical engagement and financial support in this research project. (The test site at Walenstadt is jointly operated by *Geobruigg* and the *Swiss Federal Institute WSL, Birmensdorf*).

References

- [1] EKLS 2001, Richtlinie über die Typenprüfung von Schutzbauwerken gegen Steinschlag, eds. Eidg. Expertenkommission Lawinen und Steinschlag (EKLS), Bundesamt für Umwelt, Wald und Landschaft (BUWAL), Bern, 2001.
- [2] W. Gerber, H. Grassl, A. Böll and W. Ammann, Flexible Rockfall Barriers – Development, Standardisation and Type-testing in Switzerland, *Proc. of the Int. Conf. on Landslides – Causes, Impact and Countermeasures*, eds. Kühne, M. et al., VGE Essen, 2001.